

SVEN[®]
YOU WANT – WE CAN

Game Racing Wheel

OPERATION MANUAL



DRIVER

www.sven.fi

Congratulations on the purchase of Sven product!

Please read this Operation Manual before using the unit and retain this Operation Manual in safe place for future reference.

COPYRIGHT

© 2014. SVEN PTE. LTD. Version 1.0 (V 1.0).

This Manual and information contained in it are copyrighted. All rights reserved.

TRADEMARKS

All trademarks are the property of their legal holders.

NOTICE OF RESPONSIBILITY RESTRICTION

Despite the exerted efforts to make this Manual more exact, some discrepancies may occur. The information of this Manual is given on “as is” terms. The author and the publisher do not bear any liability to a person or an organization for loss or damages which have arisen from the information, contained in the given Manual.

UNPACKING

Unpack the device carefully. Make sure there are no accessories left in the box. Check up the device for damages; if the product was damaged during transportation, address the firm which carried out the delivery; if the product functions incorrectly, address the dealer at once.

CONTENTS

1. DESCRIPTION	1
2. SAFETY PRECAUTIONS	2
3. PACKAGE CONTENTS	2
4. SPECIAL FEATURES	2
5. SYSTEM REQUIREMENTS	2
6. DESCRIPTION OF THE CONSTRUCTION	3
7. CONNECTION AND INSTALLATION	5
8. TROUBLESHOOTING	8

1. DESCRIPTION

DRIVER Game Racing Wheel is specially designed for PC. Ergonomic design with rubber coating ensures optimal comfort with solid grip. Trendy and streamline wheel design guarantees real gaming experience. 270 degree wheel rotation, adjustable sensitivity, vibration feedback function and a built-in wind conditioner create a surreal racing experience that will satisfy any driving fan.

2. SAFETY PRECAUTIONS

- Do not disassemble or repair the device on your own. Maintenance and repairs should be carried out by qualified staff of the service centre only.
- Protect the device from direct impact of high humidity, dust, strong magnetic fields, vibrations, high temperatures, toxic liquids and gases.
- Instructions for device maintenance: for cleaning the case of the device please use clean soft cloth. Do not use such solvents as gasoline or spirit for cleaning, since these solvents can damage the surface of the device.
- Do not drop the device not to have it damaged.

3. PACKAGE CONTENTS

- Game Racing Wheel — 1 pc
- Pedal unit — 1 pc
- Fixation stand — 2 pcs
- Software CD disk — 1 pc
- Operation manual — 1 pc
- Warranty card — 1 pc

4. SPECIAL FEATURES

- Compatibility with PC/PS2/PS3
- Ergonomic design of game racing wheel
- Wheel diameter – 10" (254 mm)
- Steering angle – 270 degrees
- Supports: DirectX 7.0 or higher, Windows XP/Vista/7/8
- USB Interface
- Built-in vibration feedback and cooling fan for more realistic effect
- Indication of accelerating and braking force
- Sensitivity control
- Two axes, D-Pad, Tiptronic lever for changing gears, 12 additional buttons
- Rubber coating of the wheel for comfortable driving
- 6 rubber suction caps and 2 fixation stands for secure fixation to the table
- Digital and Analog Modes available
- Foot pedal unit included
- Comfortable location on the lap

5. SYSTEM REQUIREMENTS

- USB port available
- Operational System Windows XP/Vista/7/8

6. DESCRIPTION OF THE CONSTRUCTION

- ① Racing wheel
- ② Rubber coating
- ③ Keys 1, 4
- ④ Paddle shifters
- ⑤ Ventilation grids
- ⑥ Key panel
- ⑦ Braking indication
- ⑧ Keys 2, 3
- ⑨ Lever for changing gears
- ⑩ Accelerating indication
- ⑪ Rubber suction caps
- ⑫ Keys 7–12
- ⑬ D-Pad
- ⑭ Keys 9–10
- ⑮ MODE button
- ⑯ ON/OFF MODE indication
- ⑰ Sensitivity control
- ⑱ Foot pedal port
- ⑲ Headlights
- ⑳ USB Cable
- ㉑ Brake pedal
- ㉒ Acceleration pedal
- ㉓ Foldable stand for feet

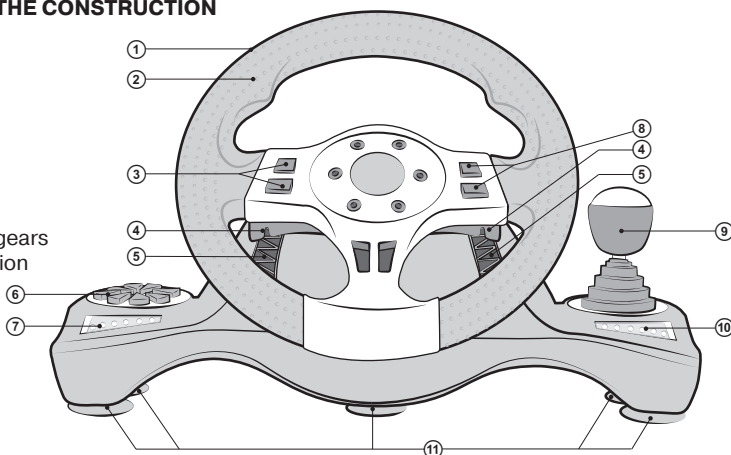

Fig. 1. Front view

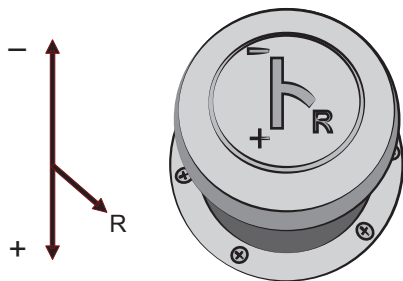
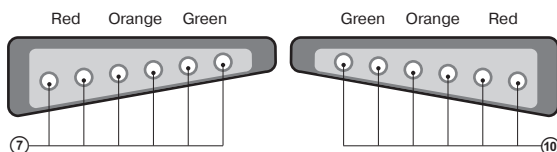

Fig. 2. Lever for changing gears

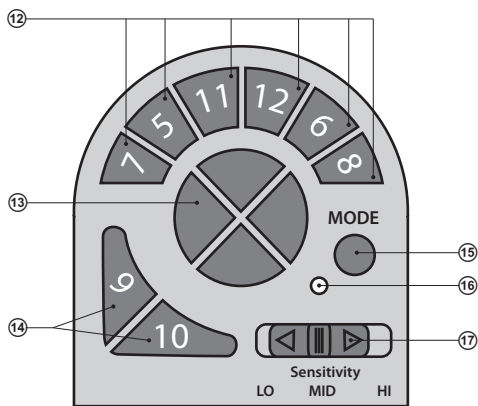

Fig. 3. Key panel

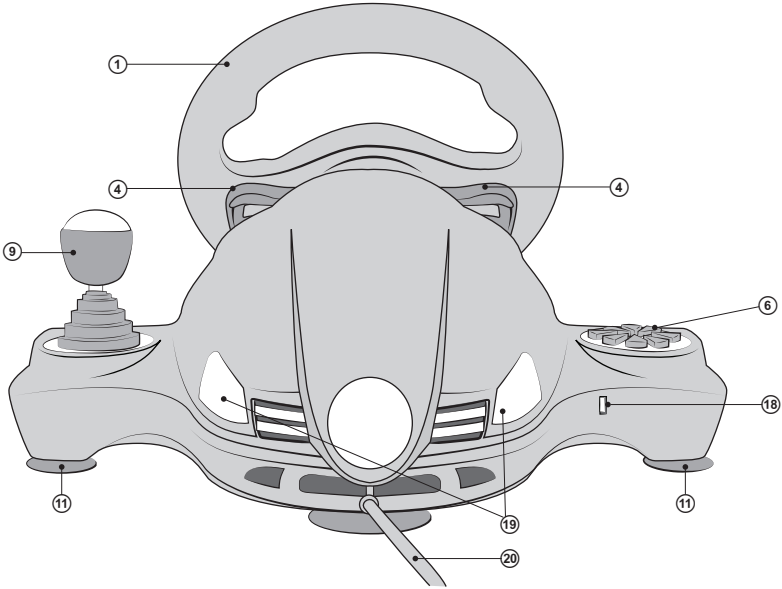

Fig. 4. Back view

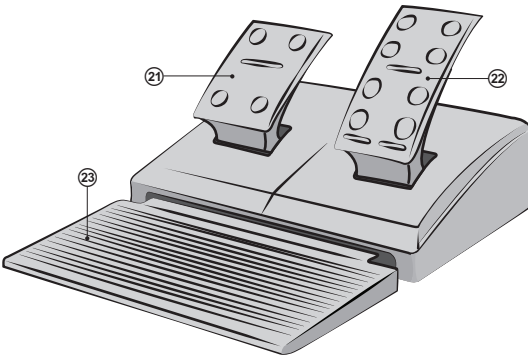

Fig. 5. Foot pedal unit

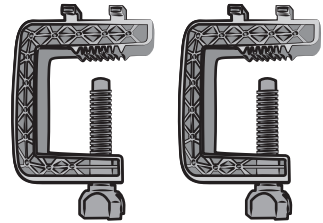

Fig. 6. Fixation stands

7. CONNECTION AND INSTALLATION

- Install the device on an even surface (for example, on a table) on its suction caps. If necessary fasten it with the two fixation stands (Fig. 6).

- Connect the pedal unit to the device (Fig. 5) via the pedal unit cable to RJ-11 jack ⑱, then connect USB cable ⑳ of the device to the available USB port of the computer.

- Insert the Software CD disk into the disk drive of your PC and launch setup.exe to install drivers on your PC. Go to the game controller settings in the control panel and Game Controllers window should appear on your PC (Fig. 7).

Wheel Test

- *Axes Test.* Pass to the “Test Page” bookmark (see Fig. 8), rotate the wheel from left to right and make sure that the X-axis (“+” cross-cursor) in the “Axes Information” window moves from left to right correctly. If the cross cursor is not at the center of the window, please enter “Calibration Page” to calibrate it.

- *Button Test.* Press the wheel buttons to see if button 1 to 12 in the “Test Page” turns red for each button action (see Fig. 8).

- *D-PAD Test.* Press each direction of the D-PAD (UP, DOWN, RIGHT, LEFT and 45 degree for each direction) to see if the cursor in «Povinfo» is moving correctly (see Fig. 8).

- *Wheel calibration.* This option is only used for calibrating wheel centering fault under analog mode (the indicator LED turns red): when the cross cursor is not centered in the X/Y Axis as seen in the interface, please press “Default” and then press “Set” (Fig. 9).

- *Motors test.* Enter “Effect Page” (see Fig. 10) to test motors. Rotate the wheel and check if the left motor vibrates. Press the left wing and right wing ④ and check if the right motor vibrates. Vibration feedback force can be changed by moving the cursor to the right or the left along the “RumbleIntensity” line (fig.10).

- *Driver Uninstall (reinstall).* Restart the driver installer. Click “No” to remove the driver. Click “Yes” to reinstall the driver (see Fig. 11).

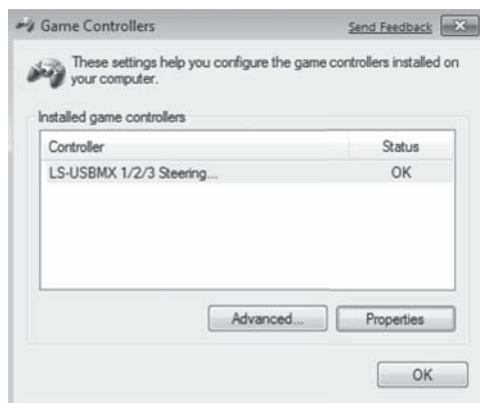

Fig. 7

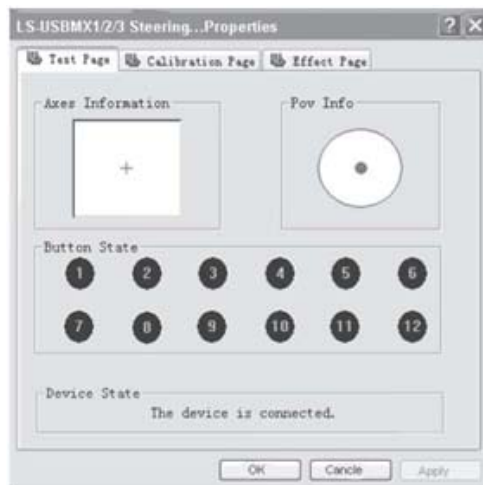

Fig. 8

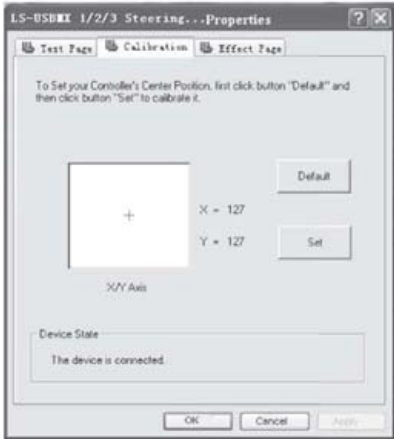

Fig. 9

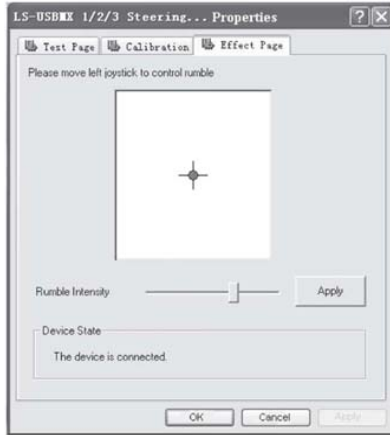

Fig. 10

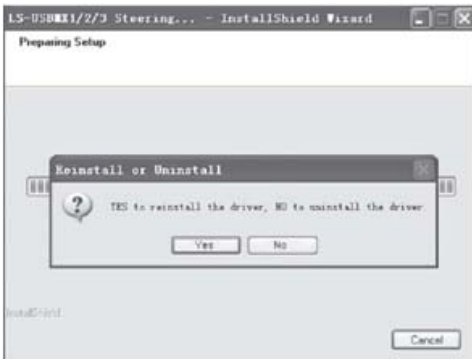

Fig. 11

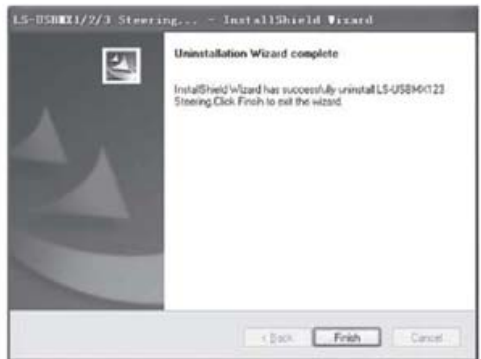

Fig. 12

• At the end in the appeared window “LS- USBMX1/2/3 steering...” (see Fig. 12) click “Finish” to confirm and quit.

Button Programming (no memory)

• Program buttons 1, 2, 3, 4, 5, 6, 7 and 8, which by default assigned functions to gear stick ⑨, left wing and right wing ④, gas pedal ⑳, brake pedal ㉑, buttons 11 and 12. Which, you define by testing. If for some reason they need to be reprogrammed, to set other functions, do the following guidelines:

- **Program Setup (no programming function under NEGCON Mode).** Enter “Test Page” (see Fig. 8), press button 9 and button 10 (14) at the same time. Hold for 3 seconds until program LED turns green. Press the programmable button. Program LED starts blinking. Press program source button. Program LED turns off. Program is set.
- **Clear Single Program.** Press button 9 and button 10 at the same time. Hold for 3 seconds and program LED turns green. Press programmable button. Program LED starts blinking. Press programmable button again. Program LED turns off. Single program is cleared.
- **Clear All Programs.** Press button 9 and button 10 at the same time. Hold for 3 second until program LED turns green. Release the buttons. Press button 10 and hold for 4 seconds. Program LED turns off. All programmed buttons are cleared. Default is restored.

Wheel Sensitivity Adjustment (3 levels):

- Wheel sensitivity can be adjusted by a toggle switch Sensitivity (17). There are 3 optional sensitivities: “LO”, “MID”, “HI”.
- By using switch Sensitivity (17) can be set three levels of sensitivity steering in position “LO” for the full twist “wheels” to turn the steering wheel to lock, i.e., all 135 degrees. In the position “MID” enough to turn the rudder to 2/3 speed, and in position “HI” maximum position is reached at the third steering.

Mode Button Function:

- The game racing wheel has two operation modes: digital and analog.

For switching to the **analog** mode:

1. Press Select + Start (9+10) buttons and hold them down within 3 seconds, the Mode indicator will light green. Then release keys 9 and 10.

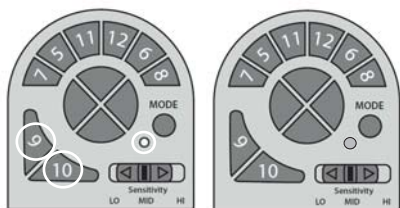

2. Push the left direction button on the digital block.



For switching to the **digital** mode:

1. Press Select + Start (9+10) buttons and hold them down within 3 seconds, the Mode indicator will light green. Then release keys 9 and 10.

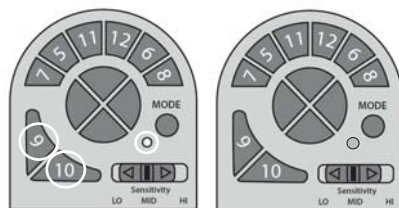

2. Press the DOWN button on the digital block.



In the digital mode the static maximum activation/deactivation of corresponding axes take place during depressing the pedal, i.e. there is only “ON/OFF” position there. In the analog mode a signal is transmitted depending on the pressure force of pedals, i.e. smoothly. The mode of buttons will not

function, when a certain mode has been already set on the console. LED indication of a mode testifies about any current active mode. The digital mode is enabled by default.

Operation without pedal unit:

- Game racing wheel is equipped with paddle shifters ④, that substitute acceleration and brake pedals: the left paddle shifter functions as a brake pedal, while the right paddle shifter functions as an acceleration pedal.

Note. Game racing wheel is equipped with braking indication ⑦ and accelerating indication ⑩ see. Fig. 1. With a smooth pressing the acceleration pedal indicator lights up green, picking up speed indicator will light orange, then red. Depending on the smoothness of dropping speed indicator lights green, orange and red colors.

8. TROUBLESHOOTING

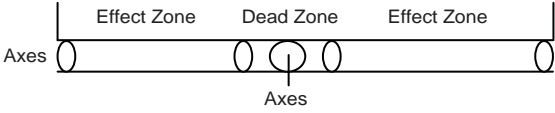
Problem	Solution
After installation of the software, game controller does not work normally.	A. Check whether the controller’s link cable is strongly connected to PC. B. Make sure that status indication for Game Controller after installation is Confirm. C. Check whether controller’s settings have no conflicts with other peripherals’ settings. D. Restart your PC, if the controller still doesn’t work normally.
Motors have no vibration function in a racing game.	After exiting the game, disconnect the controller from the USB port and connect it again. If it still can’t work normally, please restart the computer.
After entering game, some analog axis will automatically operate.	The steering wheel hasn’t been calibrated or hasn’t been confirmed after calibrations. Enter Option – Controllers – Dead Zone to adjust the range of the dead zone, and make sure the axes are in the range of the dead zone. 
After entering the game, vibration feedback operates automatically.	Enter Force Feedback and calibrate it.
During the game vibration feedback is insufficient.	Enter Force Feedback and set force of feedback.

If none of the above mentioned solutions removes the problem, please refer to nearest authorized service center for consultation by qualified specialist. Never try to repair the device on your own.

Game Racing Wheel

SVEN®
YOU WANT – WE CAN



Модель: **DRIVER**

Импортер в России: ООО «СКАНДИТРЕЛ»,
111024, РФ, г. Москва, ул. Авиамоторная, д. 65, стр. 1.
Уполномоченная организация в России: ООО «РТ-Ф»,
105082, г. Москва, ул. Фридриха Энгельса, д. 75, стр. 5.
Условия гарантийного обслуживания смотрите
в гарантийном талоне или на сайте www.sven.fi
Гарантийный срок: 12 мес. Срок службы: 2 года.
Производитель: «СВЕН ПТЕ. Лимитед»,
176 Джу Чиат Роуд, № 02-02, Сингапур, 427447.
Произведено под контролем «Свен Скандинавия
Лимитед», 48310, Финляндия, Котка,
Котлахдентие, 15. Сделано в Китае.

Manufacturer: SVEN PTE. LTD, 176 Joo Chiat Road,
№ 02-02, Singapore, 427447. Produced under the
control of Oy Sven Scandinavia Ltd. 15, Kotolahdentie,
Kotka, Finland, 48310. Made in China.

© Registered Trademark of Oy **SVEN**
Scandinavia Ltd. Finland.

DRIVER